

MULTIPURPOSE SYSTEM FOR DETECTION AND PROTECTION OF HUMAN USING WIFI WIRELESS

S.Sutheesh¹, Mr.Arockia Prasad M.E(Ph.D)²

Abstract—The multipurpose system for detection and ranging is the advanced system using the pir sensor and the esp8266 wifi which is mainly designed for the plantation workers and the fisheries. In which it will detect the animals in the rubber plantation working areas so that it will detect the entry of the animals and then pass the signal to the worker so that their life will be protected and also the economy can be developed from rubber plantations.

Keywords—Esp8266 wifi, pir sensor, led, C program, proteus software.

INTRODUCTION

The main objective of this device is that to protect the human life without affecting the animals. We had a live experience with the rubber plantation workers. In that we made research about the basic needs of the workers. We know lots of the people were attacked by the animals like elephant, wild pig. The detection system involves the sensors and the transceiving devices. The movement or the infrared signals of the animals are received by the sensor and then transmitted.

OVERVIEW OF PROTECTION SYSTEM:

The main difference from other system that it is an automatic system in which when the animal crossed through the sensed area a sudden alarm and the direction led is shown to the worker of the plantation. Here the worker is given certain trees and an area of about nearly 2 kms or more so that while working the worker will not have an aware of the animals which is going to attack them so that each worked area is sensed with the sensors which is known as the pirsensor. After sensing the signal the wifi which is connected to the sensor will transmit the signal to the worker so that the worker will get aware of the animal which is going to attack them.

HARDWARE

A. PIR SENSOR

The PIR sensor is the core part of the system. The system basically function based on infrared radiation, which is emitted from human body. PIR sensor is widely used in security system to detect the motion of human. Infrared (IR) light is electromagnetic radiation with a wavelength between 0.7 and 300 micrometers. Human beings are the source of infrared radiation. It was found that the normal human body temperature radiate IR at wavelengths of 10 micrometer to 12 micrometer. PIR sensors are passive electronic devices which detect motion by sensing infrared fluctuations.

B. PIR Details

Number of pir sensor -5,

Compact size (28 x 38 mm)

Supply current: DC5V-20V

Current drain : < 50uA

Voltage Output: High/Low level signal : 3.3V

TTL output High sensitivity

Delay time : 5s-18 minute

Blockade time : 0.5s-50s

Operation Temperature: -15oC -70oC

Infrared sensor: dual element, low noise,
high sensitivity

Light sensor: CdS photocell

C. Working Of Pir Sensor

The PIR sensor itself has two slots in it each slot is made of a special material that is sensitive to IR as shown in figure (3). The lens used here is not really doing much and so we see that the two slots can 'see' out past some distance (basically the sensitivity of the sensor). When the sensor is idle, both slots detect the same amount of IR, the ambient amount radiated from the room or walls or outdoors. When a warm body like a human or animal passes by, it first intercepts one half of the PIR sensor, which causes a positive differential change between the two halves. When the warm

¹ Department of Electrical and Electronics, St. Joseph College Of Engineering St. Joseph College Of Engineering, Beemanthangal, Chennai Beemanthangal, Chennai,

² ASSISTANT PROFESSOR, Department of EEE

body leaves the sensing area, the reverse happens, whereby the sensor generates a negative differential change. These change pulses are what is detected as in fig 1.

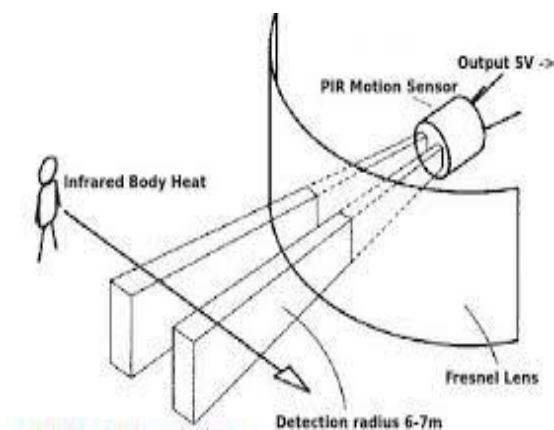

Figure:1

CONTROL UNIT

The ATmega328/P provides the following features: 32Kbytes of In-System Programmable Flash with Read-While-Write capabilities, 1Kbytes EEPROM, 2Kbytes SRAM, 23 general purpose I/O lines, 32 general purpose working registers, Real Time Counter (RTC), three flexible Timer/Counters with compare modes and PWM, 1 serial programmable USARTs , 1 byte-oriented 2-wire Serial Interface (I2C), a 6- channel 10-bit ADC (8 channels in TQFP and QFN/MLF packages) , a programmable Watchdog Timer with internal Oscillator, an SPI serial port, and six software selectable power saving modes. The Idle mode stops the CPU while allowing the SRAM, Timer/Counters, SPI port, and interrupt system to continue functioning. The Power-down mode saves the register contents but freezes the Oscillator, disabling all other chip functions until the next interrupt or hardware reset. In Power-save mode, the asynchronous timer continues to run, allowing the user to maintain a timer base while the rest of the device is sleeping. The ADC Noise Reduction mode stops the CPU and all I/O modules except asynchronous timer and ADC to minimize switching noise during ADC conversions. In Standby mode, the crystal/resonator oscillator is running while the rest of the device is sleeping. This allows very fast start-up combined with low power consumption. In Extended Standby mode, both the main oscillator and the asynchronous timer continue to run. Atmel offers the QTouch® library for embedding capacitive touch buttons, sliders and wheels functionality into AVR microcontrollers. The patented charge-transfer signal acquisition offers robust sensing and includes fully debounced reporting of touch keys and includes Adjacent Key Suppression® (AKS™) technology for unambiguous detection of key events. The easy-to-use QTouch Suite toolchain allows you to explore, develop and debug your own touch applications. The device is manufactured using Atmel’s high density non-volatile memory technology. The On-chip ISP Flash allows the program memory to be reprogrammed In-System through an SPI serial interface, by a conventional nonvolatile memory programmer, or by an On-chip Boot program running on the AVR core. The Boot program can use any interface to download the application program in the Application Flash memory. Software in the Boot Flash section will continue to run while the Application Flash section is updated, providing true Read-While-Write operation. By combining an 8-bit RISC CPU with In-System Self-Programmable Flash on a monolithic chip, the Atmel ATmega328/P is a powerful microcontroller that provides a highly flexible and cost effective solution to many embedded control applications. The ATmega328/P is supported with a full suite of program and system development tools including: C Compilers, Macro Assemblers, Program Debugger/Simulators, In-Circuit Emulators, and Evaluation kits.

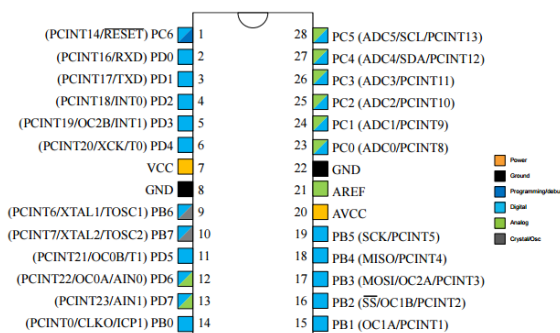

Figure:2

D. Operation of controlling unit

The Atmel 8-bit AVR RISC-based microcontroller combines 32 kB ISP flash memory with read-while-write capabilities, 1 kB EEPROM, 2 kB SRAM, 23 general purpose I/O lines, 32 general purpose working registers, three flexible timer/counters with compare modes, internal and external interrupts, serial programmable USART, a byte-oriented 2-wire serial interface, SPI serial port, 6-channel 10-bit A/D converter (8-channels in TQFP and QFN/MLF packages),

programmable watchdog timer with internal oscillator, and five software selectable power saving modes. The device operates between 1.8-5.5 volts. The device achieves throughput approaching 1 MIPS per MHz.

Microcontroller	ATmega328p
Operating Voltage	5V
Input Voltage (recommended)	7-12V
Input Voltage (limits)	6-20V
Digital I/O Pins	54 (of which 14 provide PWM output)
Analog Input Pins	28-32
DC Current per I/O Pin	40 mA
DC Current for 3.3V Pin	50 mA
Flash Memory	32 KB of which 8 KB used by bootloader
SRAM	2 KB
EEPROM	1 KB
Clock Speed	16 MHz

Table:1

ESP8266 WIFI

The ESP8266 WiFi Module is a self contained SOC with integrated TCP/IP protocol stack that can give any microcontroller access to your WiFi network. The ESP8266 is capable of either hosting an application or offloading all Wi-Fi networking functions from another application processor. Each ESP8266 module comes pre-programmed with an AT command set firmware, meaning, you can simply hook this up to your Arduino device and get about as much WiFi-ability as a WiFi Shield offers (and that's just out of the box)! The ESP8266 module is an extremely cost effective board with a huge, and ever growing, community. This module has a powerful enough on-board processing and storage capability that allows it to be integrated with the sensors and other application specific devices through its GPIOs with minimal development up-front and minimal loading during runtime. Its high degree of on-chip integration allows for minimal external circuitry, including the front-end module, is designed to occupy minimal PCB area. The ESP8266 supports APSD for VoIP applications and Bluetooth co-existence interfaces, it contains a self-calibrated RF allowing it to work under all operating conditions, and requires no external RF parts.

FEATURE OF ESP8266

802.11 b/g/n

Wi-Fi Direct (P2P), soft-AP

Integrated TCP/IP protocol stack

Integrated TR switch, balun, LNA, power amplifier and matching network

Integrated PLLs, regulators, DCXO and power management units

+19.5dBm output power in 802.11b mode

Power down leakage current of <10uA

1MB Flash Memory

SDIO 1.1 / 2.0, SPI, UART

STBC, 1x1 MIMO, 2x1 MIMO

A-MPDU & A-MSDU aggregation & 0.4ms guard interval

Wake up and transmit packets in < 2ms

Standby power consumption of < 1.0mW (DTIM3)

BUZZER

[Piezoelectric](#) buzzers, or piezo buzzers, as they are sometimes called, were invented by Japanese manufacturers and fitted into a wide array of products during the 1970s to 1980s. This advancement mainly came about because of cooperative efforts by Japanese manufacturing companies. In 1951, they established the Barium Titanate Application Research Committee, which allowed the companies to be "competitively cooperative" and bring about several piezoelectric innovations and inventions.

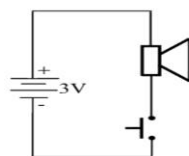

Figure:3

Programming Of The esp8266

The esp8266 wifi has been programmed using the c program and it works on the server and client system the server wifi is programmed separately. In this system the clients are connected to the server. A page requested by the client is first parsed in the server and the embedded ASP generated contents in addition to static pages. The following

C commands can be used:

```
pinMode(LED0, OUTPUT); // WIFI OnBoard LED Light
pinMode(BUTTON, INPUT_PULLUP); // Initiate Connectivity
digitalWrite(LED0, !LOW); // Turn WiFi LED Off
```

```
// Starting To Connect -----
WiFi.mode(WIFI_STA); // To Avoid Broadcasting An SSID
WiFi.begin("TAKEONE"); // The SSID That We Want To Connect To
// Printing Message For User That Connetion Is On Process -----
Serial.println("!--- Connecting To " + WiFi.SSID() + " ---!");
// WiFi Connectivity -----
CheckConnectivity(); // Checking For Connection
// Stop Blinking To Indicate Connected -----
digitalWrite(LED0, !HIGH);
Serial.println("!-- Client Device Connected --!");
CIRCUIT DIAGRAM
```

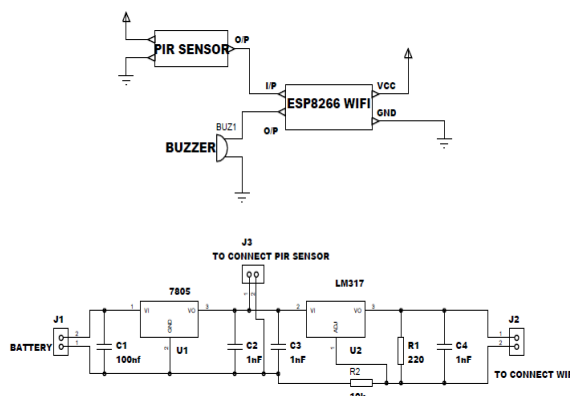

Figure:4

CONDITION	RELAY OUTPUT
If animal temperature exceeds 34°C	client 1 is ON

WORKING

The multipurpose system is which when the signal is received the data signal will be transmitted to the arduino board and the the required direction of the led will be glown. In this system when the animal crosses the pir sensor the sensed signal will be passed to the wifi and the client wifi will transmit the signal to the server wifi and then the signal will be send to the arduino board and then the recognised direction eill be processed and the based direction led will be glown.

The Arduino Integrated Development Environment (IDE) is a cross -platform application written in Java, and is derived from the IDE for the processing programming language and wiring projects. It is designed to introduce programming to artists unfamiliar with software development. It includes a code editor with features such as index highlighting, brace matching and automatic indentation. It is also capable of compiling and uploading programs to the board with a single click. Arduino programs are written in C or C++. The Arduino IDE comes with a software library called „Wiring“ from the original wiring project, which makes many input/ output operations much easier. User only needs to define two functions to make a runnable cyclic executive program. As the Arduino platform uses Atmel microcontrollers, Atmel’s development environment, AVR studio or the newer Atmel studio may also be used for the development of software for Arduino.

FEATURES

Reduced space:

Protection system are fully solid and hence extremely compact as compared to hardwire controller where in electromechanical devices are used. The wiring involved is simple and easier.

Energy saving:

Average power consumption is just 1/10th of power consumes by an equivalent relay logic control.

Ease maintainence:

- Modular replacement

- Error diagnosis with programmer supported by software
- Easy trouble shooting

Tremendous flexibility:

- To implement changes in control, no rewiring is required.
- Time consumption is less.
- ON LINE as well as OFF LINE programming is possible.
- High processing speed and greater accuracy can obtained.

EXISTING SYSTEM:

- Manual control of animal protection
- On site requirement of worker.
- Delayed operation.

Revised system:

- By introducing wireless based WIFI, an attempt has been made to rectify those problem.

CONCLUSION

By using this device lots of life will be saved.It is a cost efficient system.Valuable things can also be protected.Through this proposed system which act to limit the accidents especially after that development which adds after that can be reset the system (through using password) it can also used for the animal monitoring also and also it can be connected to webserver so that the employees in the protection and monitoring can be alerted to send the emergency purpose thing to the plantaion workers.

References

Websites

- [1] www.wikipedia.org
- [2] www.alldatasheet.com
- [3] www.edgefx.com
- [4] www.ieeexplore.org